

ISTRUZIONI PER L'INSTALLAZIONE
INSTALLATION INSTRUCTIONS
INSTALLATIONSANLEITUNG
INSTRUCTIONS POUR L'INSTALLATION
INSTRUCCIONES PARA LA INSTALACIÓN

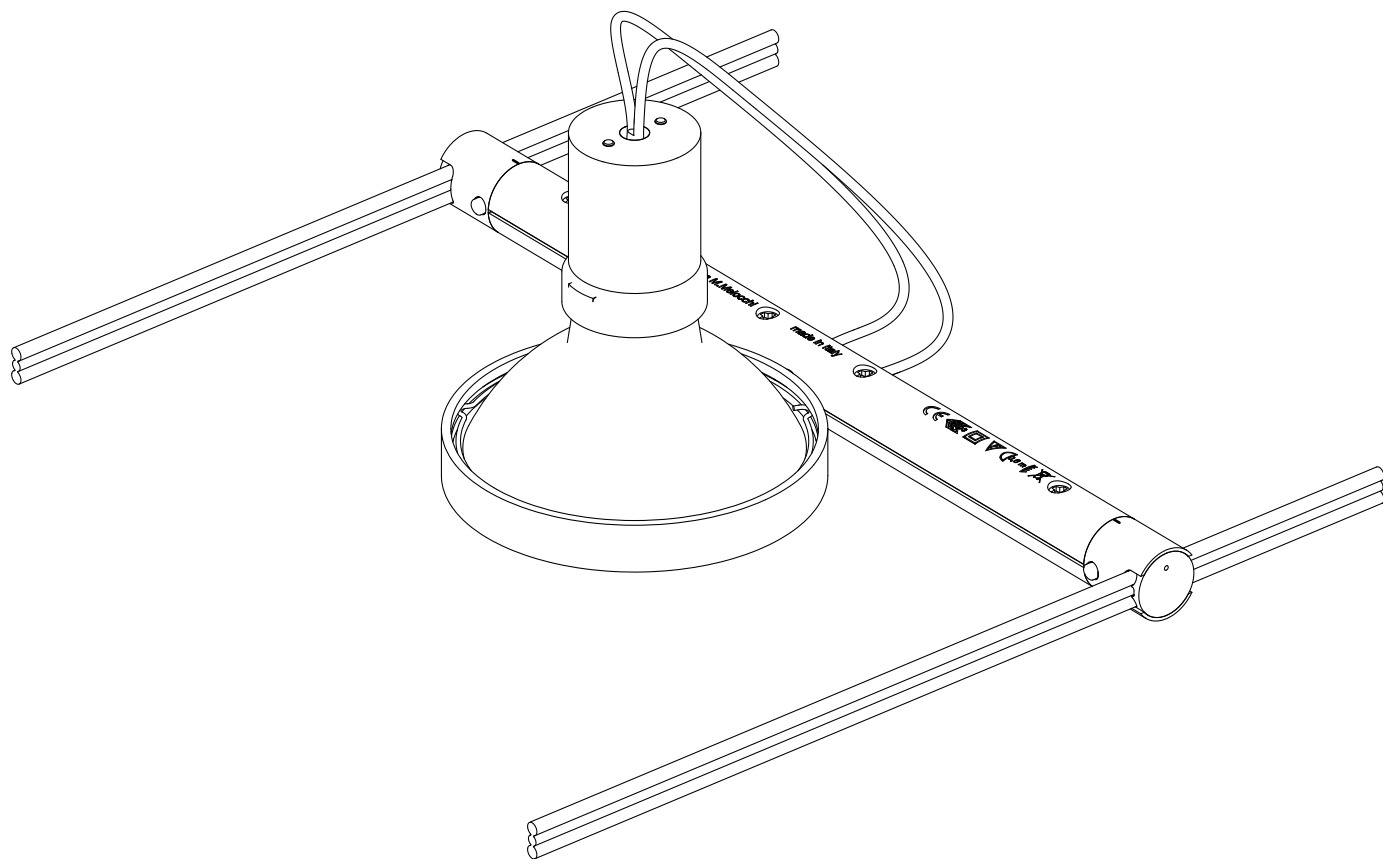

TensoSpot PAR30

con TensoCLIC®

design: LUTA BETTONICA, MARIO MELOCCHI

CE  03   IP20  0,6m

CINI & NILS®

CONTENUTO DELL'IMBALLO
 BOX CONTENTS
 PACKUNGSINHALT
 CONTENU DE L'EMBALLAGE
 CONTENIDO DE LA CONFECCIÓN



struttura
 structure
 Leuchtenkörper
 structure
 estructura



molla
 spring
 Feder
 ressort
 resorta



istruzioni
 instructions
 Montageanleitung
 instrucciones
 instrucciones



Assembler1



Assembler2



Base



Spinotto

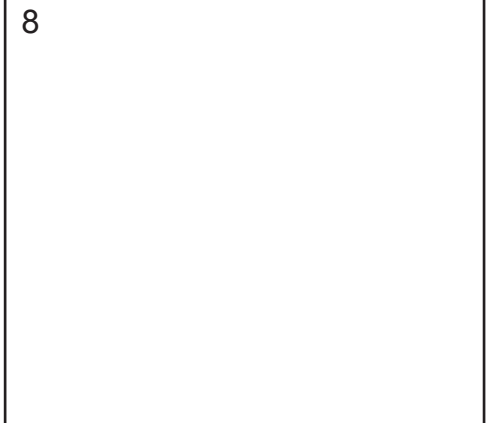
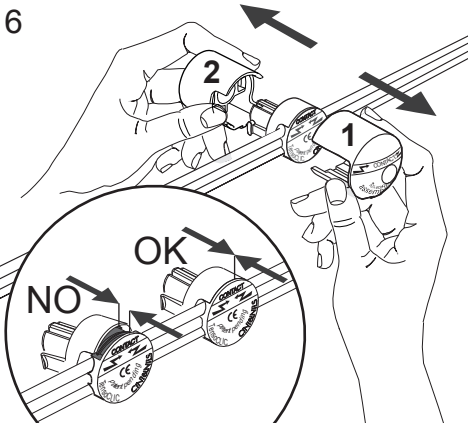
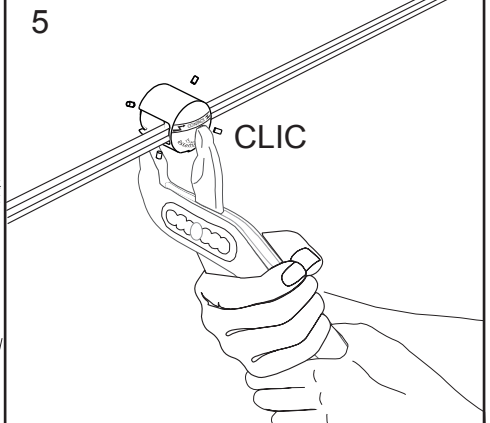
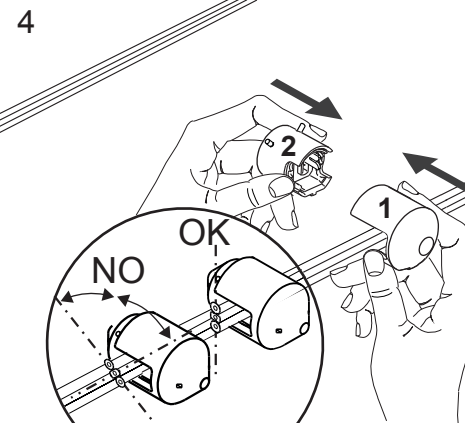
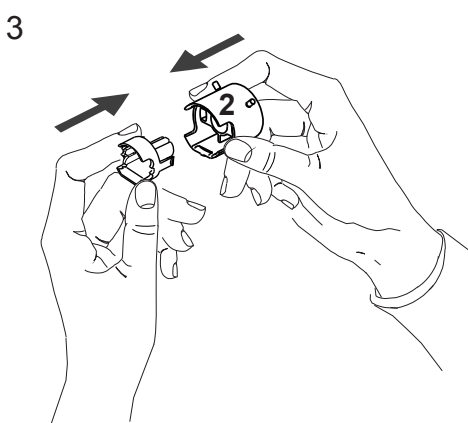
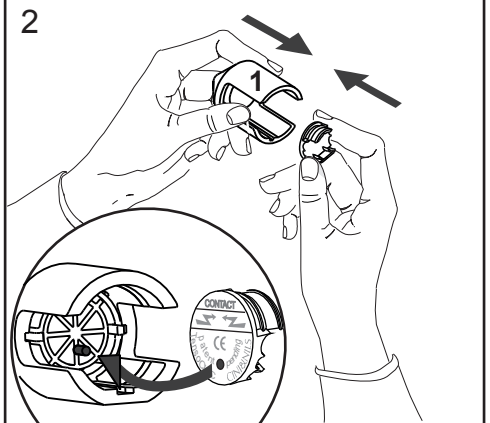
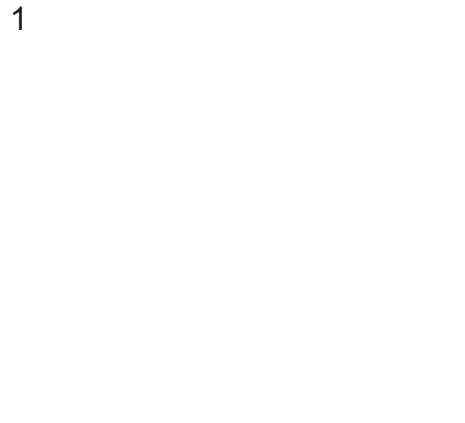
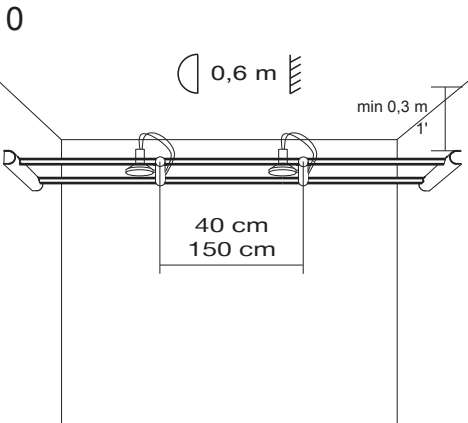
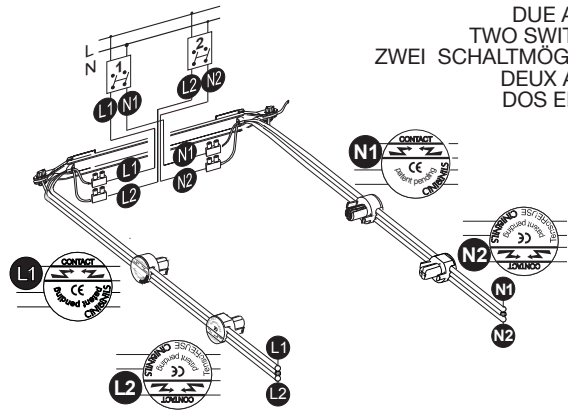

COD. 715 TensoSpot PAR30 chrome

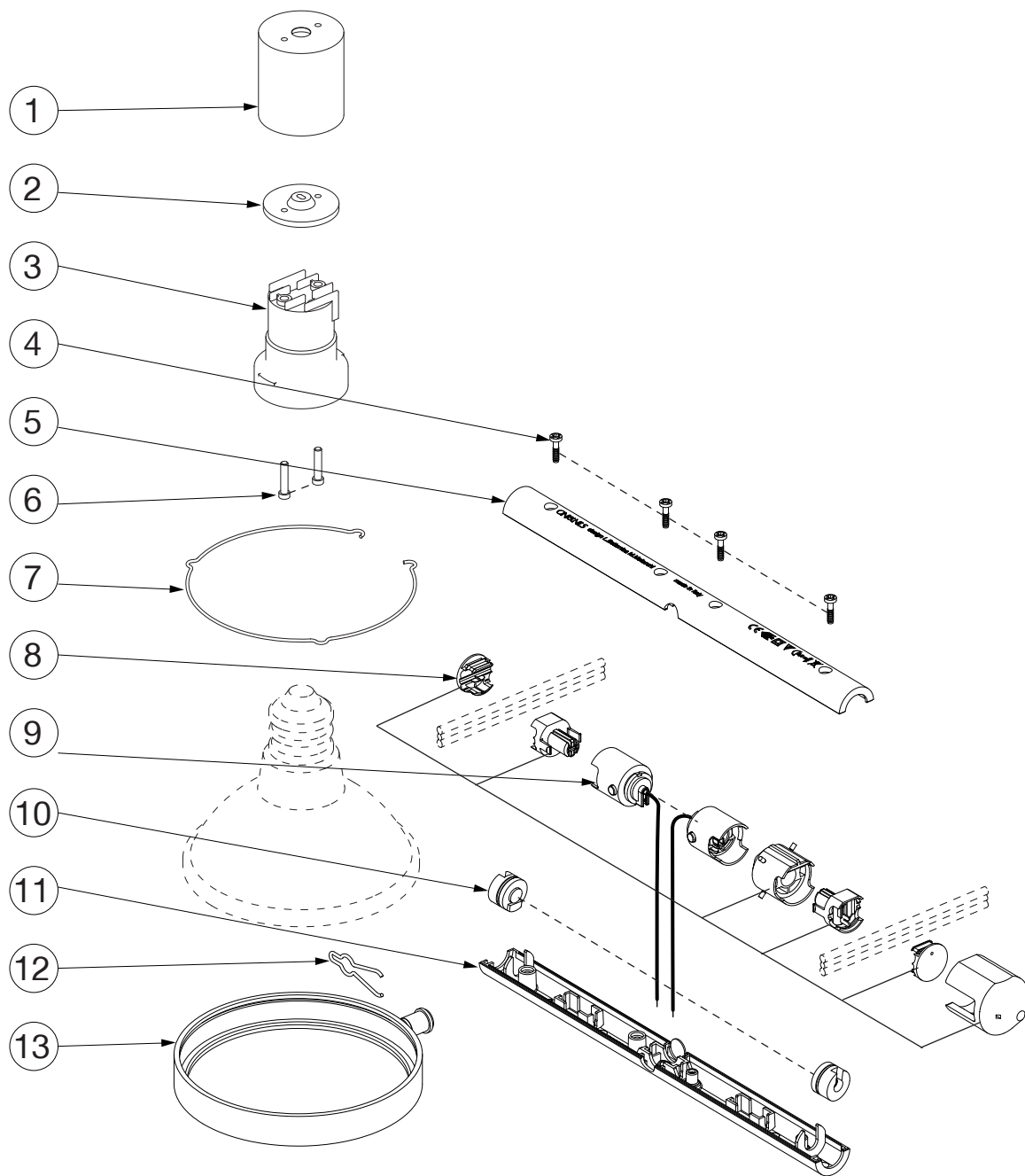

Ricambi - Spare parts - Ersatzteile - Rechangees - Recambios

Se desiderate:

- monografie
- progetti illuminotecnici
- i luoghi dove acquistare
- informazioni

chiamate il numero verde 800- 218731
da lunedì a venerdì
dalle 9 alle 13 e dalle 14 alle 18
oppure inviate un fax 02-3801.1010
e-mail: info@cinienils.com
www.cinienils.com

To ask for:

- monographs
- lighting designs
- where to buy
- information

call +39-02-334307.1
from Monday to Friday
from 9 am to 1 pm and from 2 pm to 6 pm
or write a fax to +39-02-3801.1010
e-mail: info@cinienils.com
www.cinienils.com

Sind Sie interessiert an:

- Produkt-Monographien
- lichttechnischen Planungen
- Händlerverzeichnis
- Informationen

Rufen Sie: +39-02-334307.1
Montags bis Freitags
von 9 bis 13 und von 14 bis 18 Uhr
oder Fax an: +39-02-3801.1010
E-Mail: info@cinienils.com
www.cinienils.com

Pour demander:

- des monographies
- des projets d'éclairagisme
- où acheter
- des informations

appelez +39-02-334307.1
du lundi au vendredi
de 9 h à 13 h et de 14 h à 18 h
ou envoyez un fax +39-02-3801.1010
e-mail: info@cinienils.com
www.cinienils.com

Para solicitar:

- monografías
- proyectos luminotécnicos
- nuestros distribuidores
- informaciones

llame al +39-02-334307.1
de lunes a viernes
de las 9 a las 13 horas y de las 14 a las 18 horas
o envíe un fax al +39-02-3801.1010
e-mail: info@cinienils.com
www.cinienils.com